

DOOSAN

Wheel Loaders |
DL450-5 / DL550-5



Maximum power: 345 hp / 380 hp
Operating weight: 25,730 kg / 32,770 kg
Bucket capacity: 4.5 m³ / 5.4 m³



Doosan Group – Building your tomorrow today

Be part of the great Doosan family

The Doosan Group – founded in 1896 and headquartered in Seoul, South Korea – is one of the fastest-growing companies in the world:

- With more than 43,100 employees in 34 countries, we are a major player in a variety of industries worldwide
- We are a global leader in the Infrastructure Support Business (ISB), with 56 subsidiaries and 3,700 distributors worldwide
- Dramatic growth over the past decade, with 23% average annual revenue growth since 2000 and rising from €2.4 billion in 1998 to €18.0 billion in 2011

Doosan Group – a top player worldwide



Doosan Engines

- World N° 2 in medium-speed marine diesel engines



Doosan Engineering & Construction

A pioneering leader in construction of residential and public buildings, civil works and industrial facilities.

- World N° 1 chemical process equipment products



Doosan Heavy Industries & Construction

- World N° 1 in desalination plant construction
- World N° 1 in heat recovery steam generator market
- World N° 1 in mould & tool steel
- World N° 3 in crankshafts



Doosan Infracore

- Among the world's Top 5 manufacturers of construction equipment
- World N° 1 in compact loaders
- World N° 1 in attachments
- World N° 1 in portable air compressors



Doosan Infracore Construction Equipment

Creating construction equipment for over 40 years

For over 40 years, we've been building a global production and business network to become one of the world's foremost construction equipment manufacturers.

A solid partner, close to you

A truly global player in every respect, we have large-scale factories, sales subsidiaries and dealers all over the world.



Doosan facilities in Europe

▣ **From machine manufacturer... to full solution provider**

To ensure the highest trade-in and residual values, our parts and service support professionals maintain the performance, productivity and reliability that you expect of our products throughout their lifetime.

▣ **Ask your dealer for a full range of services designed especially for you!**

As your local specialist, your dealer ensures that you receive the maximum benefit from our integrated package. Plan ahead to ensure the success of your equipment!



Doosan approved attachments



Genuine parts



Extension of warranty



Financial solutions



Maintenance contract



Telematics



Monitoring systems



▣ **Simplicity works when it comes to Doosan's product range...**



Articulated Dump Trucks



Special Applications



Wheel Loaders



Wheeled Excavators



Compact Excavators



Crawler Excavators

Raise productivity, fuel-efficiency & profits

► Productivity

Thanks to their robust design and the use of high-quality components, the Doosan wheel loaders deliver very high performance – ensuring you the best productivity and reliability.

⊙ **Z-bar:** "Z" kinematic delivers a huge break-out force, especially for heavy materials, and a large dump angle for unloading sticky materials efficiently.

⊙ **Worktools:** Wide range of heavy-duty attachments to answer all of your needs.

⊙ **Simplicity of operations:** "Lift arm raise kick-out" and "return to dig" bucket – Automated functions operated electronically from inside the cab.

⊙ **Versatility:** 3rd valve (standard) increases the versatility of your investment.

⊙ **Load Isolation System:** Ride control (standard) reduces pitch effect and vibrations to provide the best comfort.

⊙ **Automatic hydraulic differential lock:** The machine delivers all of its performance, while preserving fuel consumption by less rolling resistance.

⊙ **Hydraulic system:** Load sensing closed centre system provides the operator with precision & smoothness while reducing fuel consumption.



Total cost of ownership ▲

Minimising your operating costs is at the heart of the Doosan wheel loaders' design, every day.

⊕ **Safety:** Always a critical factor for your company and your employees – so, these machines feature large platforms, hand-rails, and 2 emergency exits, with maintenance performed from the ground.

⊕ **Spacious cab:** Operator enjoys comfortable driving, with many ergonomic features as standard.

⊕ **Power:** Exceptionally powerful, with high torque at low revs, the Stage IV compliant Scania engines do not need a Diesel Particulate Filter (DPF) and associated regeneration system, so they deliver greater fuel efficiency.

⊕ **Efficient fuel management:** This generation of Scania engines enables up to 10% fuel reduction. Engine shut-off provides an additional max. 5% reduction.

⊕ **Cooling performances:** Cooling compartment separated from the engine compartment to prevent warm and dusty air from entering and allow better control of air intake. Automatically reversing fan as standard.

⊕ **Full fenders:** As standard, to keep your machine clean and your operators even safer.

⊕ **Serviceability:** Spacious access to main components allows quick and easy daily maintenance.

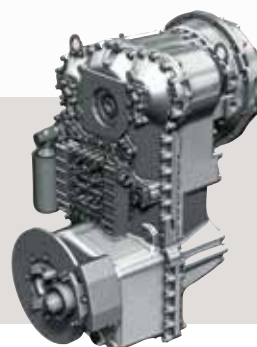

Powertrain: 5-gear ZF PowerShift transmission, with automatic and manual shift modes, plus torque converter with “lock-up” function for lower fuel consumption and an impressive speed in climb.

Top performance and fuel efficiency



Strength and intelligence – a winning combination!

Exceptional power – combined with the finest workmanship – results in a machine that performs at the highest level. The DL450-5 & DL550-5 enhance your output from every angle:

- Impressive breakout force and high traction make penetration easy and allow you to tackle the hardest materials
- Powerful hydraulic system makes work quick and efficient
- New Scania DC13 engine with SCR technology provides the power you need while meeting Stage IV environmental regulations

The combination of these features gives Doosan wheel loaders excellent penetration power, ensuring optimum bucket load in each cycle.



New engine – lower emissions / higher torque

The DL450-5 & DL550-5 are equipped with Scania engines. Renowned for excellent fuel efficiency, reliability and long service life, they combine exceptional power output with high torque at low revs. For faster machine response – even at very low speed – XPI (extra-high pressure injection) common-rail fuel injection (2400 bar) is combined with a Variable Geometry Turbocharger (VGT).

Selective Catalytic Reduction (SCR) technology, combined with a Diesel Oxidation Catalyst (DOC), ensures compliance with Stage IV environmental regulations. As there is no need for a particulate filter, there is no need for regeneration.



Tailored performance

You can select from 3 different working modes: ECO, Normal and Power, while the Power-up function lets you switch the machine into a higher working mode with lower transmission shift intervals by fully applying the acceleration pedal.

Save fuel, save money

To improve your fuel efficiency, an auto shut-down reduces the idle time of the engine, to prevent the over-consumption and useless operating hours. You can easily set the auto shut-down (to stop the engine after 3 to 60 minutes) via the LCD display.

ECO gauge

Shows the average fuel efficiency for 1 minute of operation.

Transmission

The Doosan ZF transmission has 5 gears (depending on the country) to boost acceleration performance, especially on climbs with the lock-up. The gear ratios are optimised and smooth, and shock-free shifts contribute to the high overall level of operator comfort. Traction force is also maximised.

Together, these qualities enable high working speed in all conditions. The transmission has 3 operating modes:

- Manual
- Automatic (working, 1st to 5th gear)
- Automatic (travelling, 2nd to 5th gear)

An automatic kick-down improves the machine's penetration into the pile.

Load sensing hydraulic closed centre system

This system provides maximum hydraulic performance, without producing excess capacity, thus saving fuel and extending the lifetime and reliability of vital components (such as the pumps and the main control valves).



Lock-up: The DL450-5 & DL550-5 also feature torque converter lock-up. When this is activated, the engine automatically connects directly to the transmission (depending on speed and travel resistance), even from 2nd gear. The transmission receives the full engine power without hydraulic slip – thus increasing speed on slope dramatically.

This feature can save you up to 10% in fuel costs.

Operating in comfort

▣ Comfort – why do without?

The productivity of your wheel loader is directly linked to the operator's performance. That's why Doosan has placed comfort at the very centre of its design priorities for the DL450-5 & DL550-5.

More space, better visibility, a high comfortable seat, and plenty of storage space make it easy to work for hours without fatigue or discomfort. And there's no need to pay extra for the options you want – most of them are standard features on this loader!

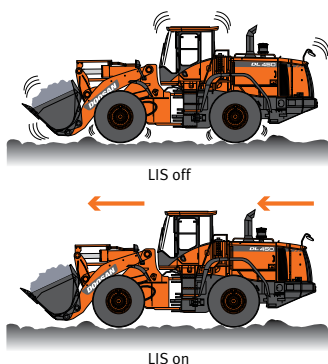

Operator environment

A modern and attractive work space offers generous headroom, and seat movement provides lots of leg room. Interior materials are selected for their high quality and easy cleaning. In addition, your belongings are right at hand, thanks to several storage boxes throughout the cab.

Comfortable automatic lift arm

Save time and reduce the number of operations with the “lift arm raise kick-out” and “return to dig” system. These functions are operated electronically from inside the cab.

High-comfort air suspension seat

With vertical and horizontal suspension, the ultra-comfortable, heated and fully adjustable Grammer seat is featured as standard, giving you the feeling of being comfortably installed in your own sofa.

Load Isolation System

This standard feature provides a smooth ride over rough ground, operator comfort, and reduced cycle times due to improved vehicle stability in movement. Higher productivity and better fuel efficiency while performing load & carry applications. Speed for automatic activation is adjustable by the operator.

Accurate & smooth joystick steering

Keep your concentration and reduce strain with the comfortable joystick steering integrated on the armrest. Drive your machine easily, especially in repetitive tasks and tight spaces.

Automatic air conditioning

Day and night, whatever the weather, set your preferred temperature for the best working conditions. Fully automatic climate control system adjusts air temperature and fan speed to maintain your ideal climate setting.

Adjustable steering column

Enhance your driving comfort, and work without fatigue, by easily adjusting the steering column's tilt and telescopic movements to fit your preferred position.

Colour LCD monitor panel

The 5.7” LCD panel is suitable for day and night work. The user-friendly monitor has two customisable screen displays (per operator's preference), giving full access to machine settings and maintenance data. Any abnormality is clearly displayed on the screen, allowing you to work safely and confidently with an accurate overview of all conditions.



1. Radio
2. Climate control HVAC
3. Storage compartment for sunglasses & sun visor
4. Colour rear-view camera
5. Opening emergency exit
6. Joystick or fingertip control
7. Large control armrest
8. Improved visibility on the bottom left & right
9. Colour LCD monitor panel

10. Multi-settings high-comfort air-suspension seat with joystick steering
11. Large storage compartments
12. Emergency engine stop switch
13. Large ergonomic pedals
14. Differential lock pedal
15. Flat, spacious, easy-to-clean floor
16. Extinguisher location
17. Fuse box

Expert control with maximum safety

▣ Safe operation in all simplicity

Power alone is not enough – for maximum efficiency, it needs to be matched by precise control. Our unique range of features allows every operator to get the most out of these impressive machines.

Safety is crucial to your company and your employees – so, these machines feature large platforms, hand-rails, and 2 emergency exits, with maintenance performed from the ground.

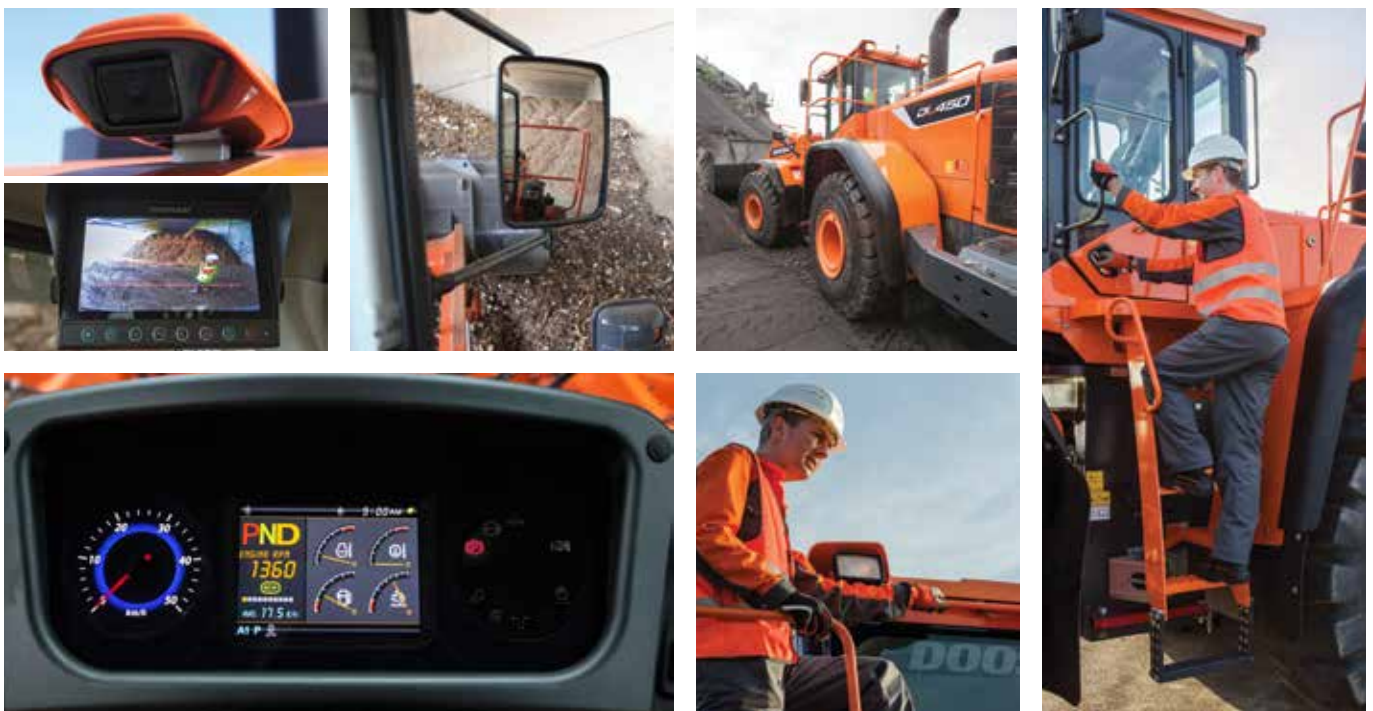

Rear view camera

A camera provides a clear view of what's happening behind the machine for added safety and peace of mind. The full colour display screen in the cabin shows the operator what the camera sees. The panoramic view shows trucks coming up behind the loader or people on the ground, and some indicators provide a good perception of distances.

External mirrors

The external mirrors are heated to ensure visibility and prevent accidents in cold weather.

Full fenders

To keep them clean and avoid mud splashing on the windows or accidents on slippery steps, Doosan's wheel loaders are standard equipped with full fenders and mud guards.

Cab

To ensure a healthy work environment, the cab air is filtered twice to eliminate all particles larger than 2 microns. Plus, the cab satisfies ROPS/FOPS regulations – a wide emergency exit (located on the right side) provides fast, easy evacuation in a critical situation.

Safe maintenance

All the daily gauges checking takes place from the ground, to be operate quickly and safely by everyone.

Doosan has also installed an automatic greasing system (as standard) to reduce working time and increase operating comfort.

Safe access

To facilitate access and mobility on the machine, multiple hand-rails ensure that the operator always has a firm support to hold on to.

Driving assistance

- Automatic transmission with smooth shift transition
- Automatic transmission kick-down
- Automatic Hydraulic Differential Lock (HDL)
- Automatic Lift-arm Suspension (LIS)
- Automatic kick-out function on lift arm
- Automatic return to dig position
- Automatic reversing fan
- Automatic greasing system
- Automatic lock-up on torque converter



Joystick steering



Joystick configuration

Ergonomic controls: All controls are placed within the operator's easy reach. Clearly positioned for comfortable access, and grouped by function, they enable safe, confident operation. The bucket is controlled by using a convenient joystick or with fingertip levers. Both include an FNR reversing switch and kick-down function.

Reliability, the habit of a lifetime

▣ Dependable performance for low lifetime cost

Doosan has been building heavy construction equipment for 40 years. This extensive experience is reflected in the superior design and development of our wheel loaders and by an extensive logistics network. Plus, our standard machines include a wide range of features at no extra cost (other manufacturers offer these only as options).



Designed to last

We pay the closest attention to the design and manufacture of structural components. Finite Element Analysis is used to ensure an extended lifetime for main structures such as the chassis, joints and lift arm. Then, after modelling, they are subjected to intensive laboratory and field testing in extreme conditions. Ongoing statistical analysis is used to continually increase reliability.

Durable steel parts

Rear parts – such as the radiator grille, engine bonnet and fenders – are made of solid steel. They're also designed for easy repair, reducing the need to replace them if they are damaged.

Automatic hydraulic differential locks

Hydraulic differential locks on the front and rear automatically engage to ensure maximum tractive effort with a lock of 100% and an easy driving. Muddy and slippery areas can be anticipate by the operator with the manual foot control.

They also reduce the risk of skidding and prevent excessive tyre wear. The brake discs in the planetary reduction gears are reinforced, ensuring long hours of operation and easy maintenance access.

Automatic Limited Slip Differential lock is also available on the DL450-5 model.

Articulation hinges

The robust hinges feature a clean and solid design – and the 40° articulation angle and steering radius are the best in their class.

Exhaust

The inner exhaust pipe sucks air out of the engine compartment through an outer pipe – this "chimney" effect provides constant air circulation and prevents deposits of flammable material on hot parts.

Auto-lube

The DL450-5 & DL550-5 are standard equipped with an automatic central greasing system: 'Auto-lube' protects components for longer machine lifetime.

ORFS (O-Ring Face Seal)

All hydraulic lines, even the low pressure circuits, are sealed with ORFS couplings to prevent leaks.



Axles cooler: To ensure you the maximum performances from your machine, even in very hard applications, the axles could be equipped with an oil cooling system and thus ensure proper operation in any conditions.

Simple maintenance with maximum uptime

▣ Excellent service accessibility

Short maintenance operations at long intervals mean you can depend on your equipment being available on-site when it's needed. Our machines are designed for simple routine maintenance, while skilled Doosan technicians are available to provide extra support when you need it. To get the most out of your machine, you can choose the package you need from a broad range of service agreements. Uptime, productivity and residual value are all maximised, making these wheel loaders an economical and rewarding choice.

Building further on the success of the Stage IIIB engines, the new Stage IV Scania engine has no need for a DPF filter to meet the Stage IV emissions requirements. Which means no maintenance required – resulting in more uptime!



Maintenance access made simple

- The front and rear of the radiator – which is made of aluminium for the highest pressure resistance and a long lifetime – are easily accessible
- Air enters through the side and top. Swing doors provide easy access for maintenance
- A battery cut-off switch makes it easy to disconnect the battery during long-term storage
- The hour meter display can be easily checked without turning the engine on

Triple-element air filter

The forced-air cleaner removes 99% of particles and is backed up by a turbo pre-filter. Cleaning and cartridge replacement are only needed at long intervals.

Engine

The Scania EMS (Engine Management System) uses a CAN (Controller Area Network) to provide a constant flow of operating information as well as diagnostic and ECU programming functions.

Urea tank

Connected to the ECU, sensors in the tank detect low levels of AdBlue® and any system malfunction.

Global Doosan network

With a network of Doosan dealers & Parts Distribution Centres worldwide, your Doosan wheel loader can be serviced & maintained wherever you are. Our service centre in the heart of Europe has more than 40,000 parts in stock to supply you with top-quality components as quickly as possible.

Full solution provider

- The Doosan Telematic system is available as standard – offering you all of the features for reading out vehicle operating & production parameters remotely, and providing you with total ease-of-mind
- Protection+ : an extended warranty covering parts, travel and service (check with your local dealer)
- Maintenance contract: your dealer will support you with routine service at regular intervals
- Genuine parts: manufactured and tested to ensure they always meet the same high quality standards as the original components

Reversing 90° swing fan

The fan is located behind the radiator, and air is sucked in from the sides, not from behind the machine. Easier cleaning access to one-block radiator from the rear and the front. The operator can easily set standard intervals for fan reverse from the LCD display. Performance is regulated for lower fuel consumption and shorter warm-up periods.

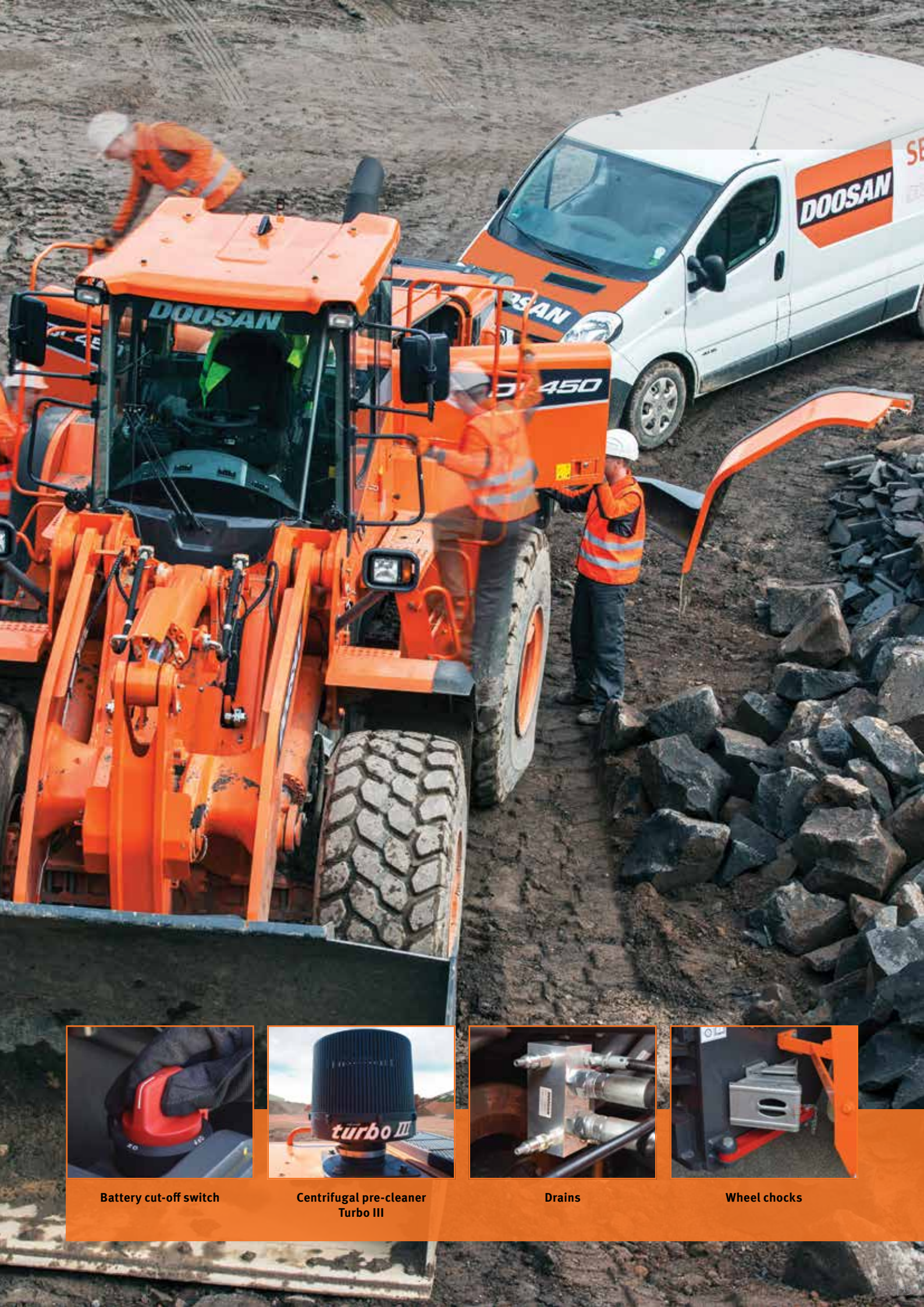

Battery cut-off switch



Centrifugal pre-cleaner
Turbo III



Drains



Wheel chocks

Technical specifications

Engine

Scania Stage IV (Tier 4 final) compliant diesel engine fully meets the latest emissions regulations.

XPI direct injection (Extra high Pressure Injection) ensures very good fuel efficiency. Variable Geometry Turbocharger (VGT) delivers high power and strong torque, even at low idle.

Electronic engine controls optimise machine performance and manage the catalytic operations by a Diesel Oxidation Catalyst (DOC) and a Selective Catalytic Reduction (SCR)

	DL450-5	DL550-5
Model	Scania DC13	
Regulation compliant	Stage IV	
No. of cylinders	6	
Nominal power - Gross (SAE J1995)	345 hp (257 kW) at 1800 rpm	380 hp (283 kW) at 1.800 tr/min
Maximum torque - Gross	1600 N.m at 1400 rpm	1765 N.m at 1.300 rpm
Idle (low - auto idle - high)	750 - 950 - 2200 [±20] rpm	
Displacement	12.7 litres	
Bore × stroke	130 mm × 160 mm	
Starter	24 V - 6 kW	
Batteries - Alternator	2 × 12 V, 200 Ah - 28 V, 100 Ah	
Air filter	Centrifugal pre-cleaner Turbo III with 2-stage Donaldson dry filter.	
Cooling	Cooling package with automatic reversing fan to facilitate radiator cleaning. Automatic rotation speed adjustment according to temperature conditions.	

Transmission

5-Gear powershift transmission with 3 operating modes: manual, fully automatic or semi-automatic with "kick-down" function.

Based on high-quality components. Equipped with a modulation system for protection and smooth gear and direction changes. A manual transmission control lever is located to the left of the steering wheel. Direction change function also available in automatic or semi-automatic mode. Transmission can be disengaged by the brake pedal to deliver full engine power to the hydraulics system. A safety device prevents the engine from starting if the transmission is not in neutral. Torque converter lock-up function from 2nd to 5th gear. Transmission testing and adjustment equipment available.

	DL450-5	DL550-5
Type	ZF 5 WG 260 + lock-up	ZF 5 WG 310 + lock-up
Torque converter	Simple stage / mono phase / fixed wheel stator	
Speeds - Forward 1-2-3-4-5	6.5 - 12.0 - 19.0 - 26.5 - 37.0 km/h	
Speeds - Reverse 1-2-3	6.5 - 12.0 - 26 km/h	
Maximum traction	23.6 t	31.0 t
Maximum gradeability	58% / 30°	

Axles

Front & rear axles manufactured by ZF with outboard planetary reduction gears. The front and the rear are equipped with Hydraulic Differential Lock (HDL), which means the machine has the best traction with few rolling resistance.

From 23.6 t to 31.0 t traction power allows operation on slopes of 51%.

	DL450-5	DL550-5
HDL lock ratio	100% (Front)	
LSD lock ratio	30% (Front & Rear)	
Oscillation angle	+/- 11°	+/- 10°

Hydraulic system

	DL450-5	DL550-5
Type	Load sensing - closed centre hydraulic system	
Main pump	Dual variable displacement axial pistons pumps	
Maximum flow	476 l/min	480 l/min
Maximum pressure	315 bar	315 bar
Pilot system	Automatic functions for positioning the bucket ready to dig and a function for stopping the lift arm at the desired height, and low position adjusted manually by switch, are standard.	
Filtration	In the oil return to the tank, the fibre glass filter has a filtering capability of 10 micron.	

Lift arm

Z-kinematics with simple lifting piston system designed for heavy-duty applications. 23.1 & 24.7 tons breakout force combined with a bucket angle that is maintained throughout the range of movement. Bucket angles are optimised in the travelling position and at ground level. Load Isolation System (LIS) is fitted as standard for improved operator comfort, output and lifetime.

Load cycle

	DL450-5	DL550-5
Lift arm - up	6.3 s	6.4 s
Lift arm - down	3.0 s	4.2 s
Bucket - crowd	2.3 s	2.1 s
Bucket - dump	1.6 s	1.4 s

Hydraulic cylinders

	Quantity	DL450-5 Bore × rod diameter × stroke (mm)	DL550-5 Bore × rod diameter × stroke (mm)
Lift	2	170 × 105 × 789	190 × 105 × 890
Bucket	1	190 × 120 × 590	220 × 130 × 610

Brakes

Dual multi-disc circuit with sintered metal discs for extended service life. Braking system activated by a pump and accumulator circuits. Spring-applied, hydraulically released parking brake is mounted on the transmission shaft and accumulator circuits and is electronically activated.

Brake type: spring-applied / hydraulically released.

Brake pump with variable displacement axial pistons provide 60 l/min.

Operator can activate/deactivate the Clutch Cut Off on the brake pedal from a switch and can adjust the sensor proximity with the same switch.

The emergency brakes are composed of a double system continually under pressure by accumulators.

	DL450-5	DL550-5
Braking distance	9.0 m at 36 km/h	11.0 m at 32.4 km/h
Number of disc brakes per wheel (front / rear)	9 / 9	7 / 7
Accumulators	0.75 l - 30 bar	

➤ Cab

Safety compliance with Roll Over Protection System (ROPS) and Falling Object Protective Structure (FOPS) requirements.

Spacious modular cab with excellent all-round visibility and ample storage space. Good overview of the bucket, tyres and loading area thanks to wide windows. Push-button controlled air conditioning and heating with air recirculation function. Double cab air filter installed in the cab with extra protection for the operator in dusty or polluted environments. Viscous suspension mount for maximum comfort. Adjustable high-quality heated seat with air suspension, arm rests and height and tilt adjustable steering column. All operating information clearly displayed in front of the operator. Control functions are centralised on a console on the right.

	DL450-5	DL550-5
Safety standards	ROPS ISO 3471:2008 FOPS ISO 3449	
Door	1	
Emergency exits	2	

➤ Noise emissions

	DL450-5	DL550-5
A weighted emission sound pressure level at the operator's position, LpAd (ISO 6396)	Declared: 73 dB(A) Measured: 72 dB(A)	Declared: 72 dB(A) Measured: 71 dB(A)
A weighted emission sound power level at external position, LwAd (ISO 6395)	Declared: 106 dB(A) Measured: 104 dB(A)	Declared: 107 dB(A) Measured: 106 dB(A)

➤ Fluid capacities

	DL450-5	DL550-5
Fuel tank	336 l	441 l
Urea (AdBlue®) tank	60 l	60 l
Cooling system	60 l	60 l
Engine oil	38 l	45 l
Front axle	42 l	62.5 l
Rear axle	42 l	64 l
Hydraulic tank	230 l	247 l
Transmission oil	54 l	54 l

➤ Steering system

	DL450-5	DL550-5
Type	Load sensing with amplification stage and priority valve	
Steering angle	40°	
Oil flow	210 l/min	270 l/min
Operating pressure	200 bar	200 bar
Steering cylinders (2)	Emergency steering system with electric motor-driven hydraulic pump.	
Bore × rod diameter × stroke	100 × 50 × 450	110 × 60 × 465

➤ Pressure settings

	DL450-5	DL550-5
Working (pump cut-off)	315 ± 10 bar	275 ± 10 bar
Steering relief – LS port side	185 ± 5 bar	185 ± 5 bar
Steering relief – steering pump side	200 ± 10 bar	200 ± 10 bar
Pilot control	30 ± 2 bar	30 ± 2 bar
Brake accumulator charging	100~160 bar	100~160 bar
Service brake	80 ± 3 bar	80 ± 3 bar
Fan motor	150 ± 10 bar	155 ± 10 bar
Parking brake release	120 ± 5 bar	120 ± 5 bar
Transmission selection pressure	17 ± 1 bar	17 ± 1 bar



Technical specifications

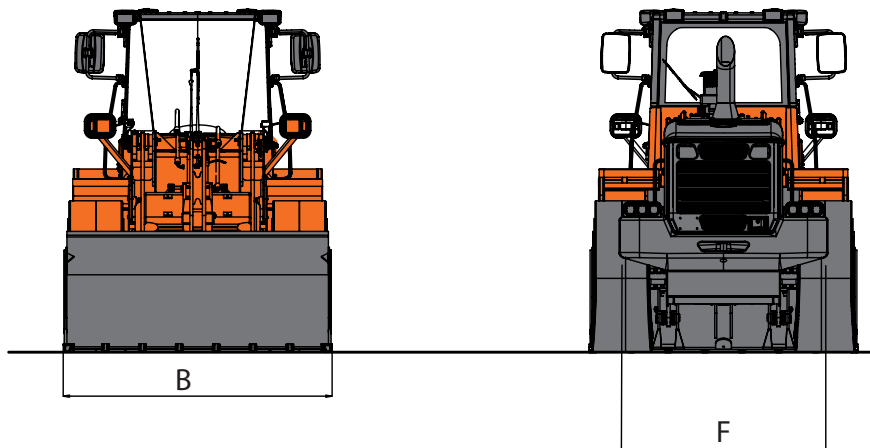
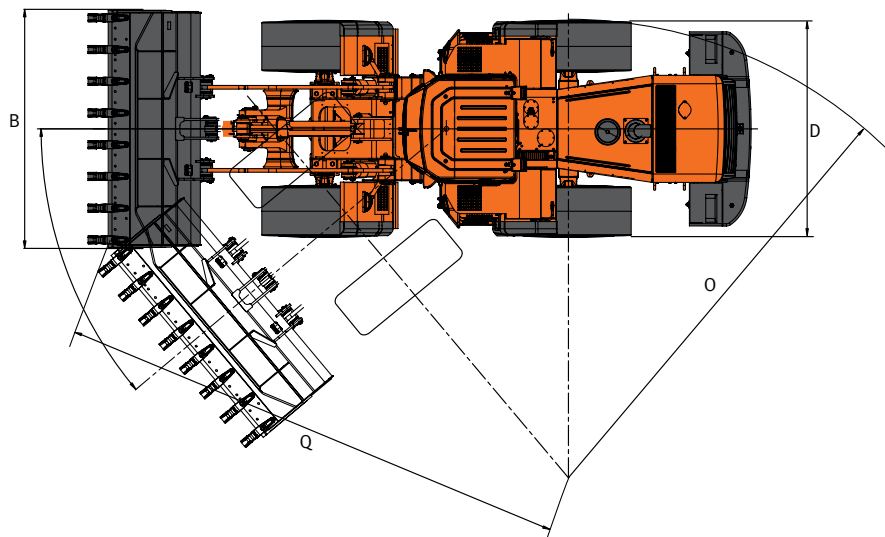
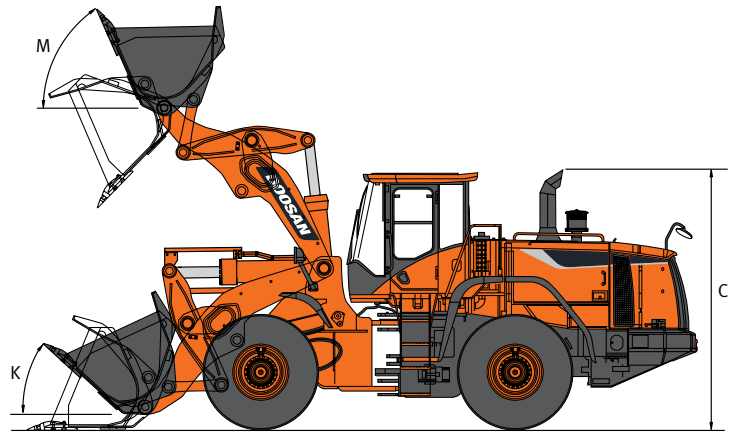
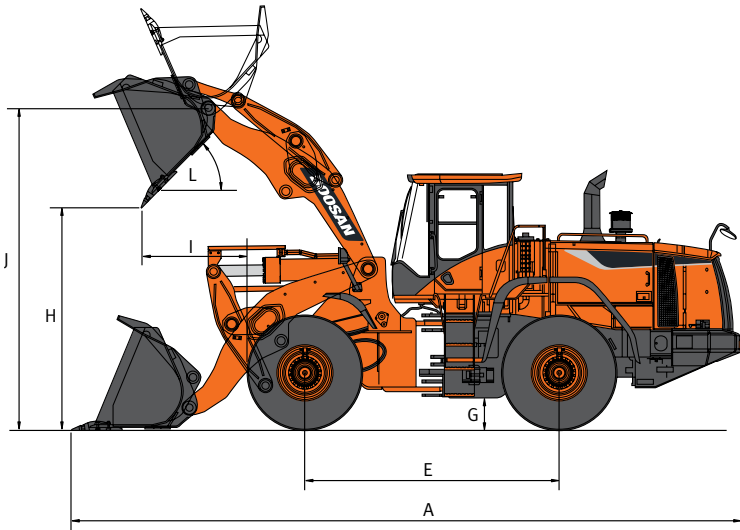

➤ Dimensions and operational data

DL450-5 – Pin-on		General purpose			Rock	High Lift
Configuration			Teeth	Cutting edge	Teeth	Cutting edge
	Capacity heaped ISO/SAE	m ³	4.5	4.8	4	4.8
B	Bucket width	mm	3300	3300	3340	3300
	Breakout force	kN	231	231	230	228
	Static tipping load (straight)	kg	20615	20515	20475	19460
	Static tipping load (at full turn)	kg	18205	18115	18080	17180
H	Dump height (at 45° – fully raised)*	mm	3115	3240	3105	3730
I	Dump reach (at 45° – fully raised)*	mm	1420	1280	1430	1480
	Dump height (at max. dump) – (at max. reach)*	mm	605	780	595	810
	Dump reach (at max. dump) – (at max. reach)*	mm	1665	1595	1650	2255
	Digging depth	mm	110	105	165	270
J	Height at bucket pivot point	mm	4500	4500	4500	4985
	Max. tilt angle in carry position	°	50	50	50	51
M	Max. tilt angle fully raised	°	66	66	66	63
K	Max. tilt angle on ground	°	45	45	45	44
	Max. tilt angle at max. reach	°	71	71	69	61
	Max. dump angle at max. reach	°	70	70	70	64
	Max. dump angle on ground	°	69	69	69	71
L	Max. dump angle fully raised	°	45	45	45	45
O	External radius at tyre side	mm	6540	6540	6540	6540
Q	External radius at bucket edge	mm	7205	7160	7155	7420
E	Wheel base	mm	3550	3550	3550	3550
D	Width at tyres	mm	2975	2975	2975	2975
F	Tread	mm	2300	2300	2300	2300
G	Ground clearance (at 12° osc.)	mm	455	455	455	455
A	Overall length	mm	9340	9155	9350	9755
C	Overall height	mm	3583	3583	3583	3583
	Operating weight	kg	25730	25795	25870	26135

(*): measured to the tip of the bucket teeth or bolt-on edge. Tyre size 26.5 R25 (L3)

DL550-5 – Pin-on		General purpose					Rock	High Lift	
Configuration			Teeth	Cutting edge	Teeth	Teeth & segments	Cutting edge	Teeth	Cutting edge
	Capacity heaped ISO/SAE	m ³	5.4	5.7	5.0	5.2	5.2	4.5	5.7
B	Bucket width	mm	3405	3405	3405	3405	3405	3405	3405
	Breakout force	kN	247	246	269	267	269	252	253
	Static tipping load (straight)	kg	26244	25874	26534	25914	26069	26294	21464
	Static tipping load (at full turn)	kg	22905	22575	23160	22615	22750	22950	18685
H	Dump height (at 45° – fully raised)*	mm	3285	3405	3355	3480	3355	3330	3830
I	Dump reach (at 45° – fully raised)*	mm	1535	1400	1460	1325	1460	1545	1620
	Dump height (at max. dump) – (at max. reach)*	mm	685	855	785	955	785	730	870
	Dump reach (at max. dump) – (at max. reach)*	mm	1830	1750	1790	1710	1790	1855	2295
	Digging depth	mm	80	80	80	80	80	45	205
J	Height at bucket pivot point	mm	4795	4795	4795	4795	4795	4795	5220
	Max. tilt angle in carry position	°	48	48	48	48	48	48	50
M	Max. tilt angle fully raised	°	67	67	67	67	67	67	62
K	Max. tilt angle on ground	°	43	43	43	43	43	43	43
	Max. tilt angle at max. reach	°	68	68	68	68	68	68	62
	Max. dump angle at max. reach	°	68	68	68	68	68	68	65
	Max. dump angle on ground	°	79	79	79	79	79	79	79
L	Max. dump angle fully raised	°	47	47	47	47	47	47	47
O	External radius at tyre side	mm	6550	6550	6550	6550	6550	6550	6550
Q	External radius at bucket edge	mm	7565	7515	7525	7530	7485	7555	7790
E	Wheel base	mm	3700	3700	3700	3700	3700	3700	3700
D	Width at tyres	mm	3180	3180	3180	3180	3180	3180	3180
F	Tread	mm	2420	2420	2420	2420	2420	2420	2420
G	Ground clearance (at 12° osc.)	mm	480	480	480	480	480	480	480
A	Overall length	mm	9870	9680	9760	9575	9760	9805	10255
C	Overall height	mm	3785	3785	3785	3785	3785	3785	3785
	Operating weight	kg	32770	32890	32595	32840	32760	32930	33670

(*): measured to the tip of the bucket teeth or bolt-on edge. Tyre size 29.5 R25 (L5)

Attachments

▣ A Doosan attachment for optimum performance in each activity

Robust construction, excellent penetration, covering several types of applications from light- up to severe-duty. These new Doosan loader attachments are designed and manufactured in Europe to meet local requirements and standards. A large range of attachments guarantees versatility and efficiency all the way. Each bucket is designed for a specific machine model to fit its key kinematic parameters perfectly. Critical bucket positions are optimised to improve digging and dumping. The Doosan attachment concept stands for high quality, perfect fit and excellent operational capabilities.



General purpose buckets

General purpose buckets provide good all-round performance for stockpiling and material-handling operations. With its sloped bottom design for optimum bucket filling capabilities and load retention, this is the perfect bucket for day-to-day material handling. It can be equipped with optional teeth, shrouds and cutting edge, depending on the customer's requirements.



Heavy-duty buckets

Heavy-duty bucket suitable for a range of applications that require a robust construction (such as sand handling or occasional severe loading). Parts subjected to high stress – such as the edge, sidebars and corner protections – are made of hardened steel. Optional teeth, shrouds and reversible cutting edge allow you to tailor the bucket to the customer's needs.



V-shape Rock buckets

Used for handling and digging of hard compacted material and blasted rock in mining or quarry applications, where high break-out force is required. Severe digging is no problem for this tough bucket, made entirely of highly wear-resistant steel with a hardness of 420 BHN. Weld-on ESCO® teeth come standard.



Light material buckets

When you need to move large amounts of light material, this bucket is the most profitable and rewarding choice. Its convex sides allow high capacity and avoid material spilling. Comes standard with a bolted reversible cutting edge.



High dump bucket

The high dump bucket is suitable for light material handling applications. This bucket improves the unload height and increases the versatility of the wheel loader. Its convex sides allow high capacity and avoid material spilling. Comes standard with a bolted reversible cutting edge.



Block forks

These forks are used to handle blocks in quarry applications. Subject to heavy constraints, these forks are strengthened and well suited with the optimized Z-bar on large wheel loaders.



Log grabs

Log grabs are designed to handle easily and safely all kind of trunks for forestry applications. Available with different configurations, they are manufactured of hardened steel to endure high stress.



↪ Bucket selection chart DL450-5

Lift arm	Bucket	Type	m³	Material Density [t/m³]															
				1.0	1.1	1.2	1.3	1.4	1.5	1.6	1.7	1.8	1.9	2.0	2.1	2.2	2.3	2.4	
Standard lift arm	General purpose	Teeth	4.5								5.2 m³					4.3 m³			
		Cutting edge	4.8							5.5 m³				4.6 m³					
	Rock	V-Type	4.0								4.6 m³					3.8 m³			
High lift arm	General purpose	Teeth	4.5				5.2 m³			4.3 m³									
		Cutting edge	4.8			5.5 m³			4.6 m³										
	Rock	V-Type	4.0				4.6 m³					3.8 m³							

↪ Bucket selection chart DL550-5

Lift arm	Bucket	Type	m³	Material Density [t/m³]															
				1.0	1.1	1.2	1.3	1.4	1.5	1.6	1.7	1.8	1.9	2.0	2.1	2.2	2.3	2.4	
Standard lift arm	General purpose	Teeth	5.4								6.2 m³				5.1 m³				
		Cutting edge	5.7							6.6 m³				5.4 m³					
		Teeth	5.0									5.8 m³					4.8 m³		
		Teeth & segments	5.2								6.0 m³						4.9 m³		
		Cutting edge	5.2								6.0 m³						4.9 m³		
	Rock	V-Type	4.5									5.2 m³					4.3 m³		
	Hard facing (WC)	Teeth	5.4								6.2 m³				5.1 m³				
		Cutting edge	5.7							6.6 m³				5.4 m³					
High lift arm	General purpose	Teeth	5.4				6.2 m³					5.1 m³							
		Cutting edge	5.7			6.6 m³			5.4 m³										
		Teeth	5.0					5.8 m³								4.8 m³			
		Teeth & segments	5.2					6.0 m³								4.9 m³			
		Cutting edge	5.2					6.0 m³								4.9 m³			

Compliant with ISO 14397-1 (2007). The filling factor depends on the type of material, the working conditions and the experience of the operator.



↪ Density of operating materials

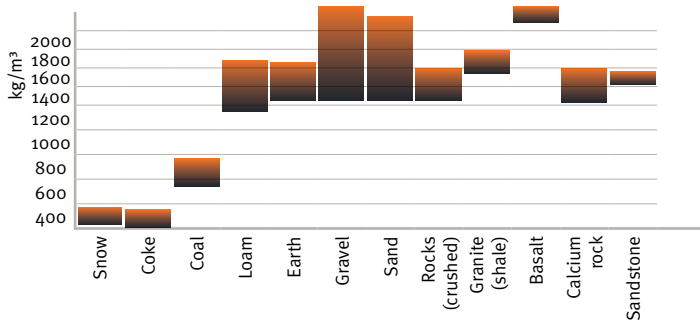

The specific weight of the material largely depends on the level of humidity, the degree of compaction, composition, etc.

Standard and optional equipment

➤ Performances

	DL450-5	DL550-5
Scania, Stage IV compliant, SCR, EGR, DOC, water-cooled, diesel engine with Variable Turbo Charger and air-to-air intercooler	●	●
No DPF	●	●
Engine power mode selector switch (Standard / Economy & Power mode)	●	●
Power-up pedal function by full stroke of acceleration	●	●
Auto shut-off engine	●	●
Fuel heater	○	○
Torque converter lock-up	●	●
Transmission clutch cut-off via the brake pedal	●	●
Transmission mode selector switch (Manual / Auto 1 ↔ 5 / Auto 2 ↔ 5 with kick-down)	●	●
Hydraulic load sensing system, variable displacement pump	●	●
Hydraulic lock differentials on front & rear axles	●	●
Limited slip differentials on front & rear axles	○	○
Axle oil cooling system	○	○
Counterweight	●	●
Robust Z bar lifting system	●	●
High lift loader	○	○
Quick coupler	○	○
Wide range of buckets	○	○

➤ Comfort

Load isolation system (LIS)	●	●
Automatic lift arm kick-out	●	●
Automatic return to dig	●	●
Levelling function	●	●
3 rd hydraulic function	●	●
Automatic air conditioning with electronic climate control	●	●
Grammer air-suspension seat with safety belt 2 points	●	●
Electric joystick steering on armrest	●	●
Mono control lever with FNR switch	●	●
Fingertip levers	○	○
Adjustable steering column (tiltable & telescopic)	●	●
Tinted safety glass	●	●
Left sliding window	●	●
Right opening window (180°)	●	●
Floor mat	●	●
Multiple storage compartments	●	●
Cup holder	●	●
Loudspeakers and connections for radio	●	●
Shark antenna for radio	●	●
Lift arm float kick-out	●	●
Alternator 28 V / 100 Ah	●	●
Dashboard monitoring with LCD display (dials, gauges and lamps)	●	●
Interior cab light	●	●
Cigarette lighter and 12 & 24 Volt power sockets	●	●
Weighing system	○	○

➤ Safety

Emergency steering pump driven by electric motor	●	●
Full fenders with rubber protection	●	●
ROPS cab (SAE J 394, SAE 1040, ISO 3471)	●	●
FOPS cab (SAE J 231, ISO 3449)	●	●
Double filtered air cab	●	●
Right opening window (emergency exit)	●	●
Front and rear wiper and washer	●	●
Retractable roller sun visor	●	●
Road lights: low and high beam, tail indicators, stop, reversing lights	●	●
Work lights: 2 halogen at the front and 4 at the rear (6 × 70 W)	●	●
Work lights: 2 xenon at the front and 4 halogen at the rear (6 × 70 W)	○	○
Reverse travel alarm	●	●
Rotating beacon	●	●
Horn	●	●
Heated external mirrors	●	●
Interior rear view mirrors	●	●
Anti-slip steps & platforms	●	●
Starting safety system	●	●
Engine exhaust brake	●	●
Brake circuits with accumulator	●	●
Dual service brake pedals	●	●
Electric parking brake on the transmission, spring-applied hydraulic release	●	●
Wheel chocks	●	●

➤ Other

Bottom protection plates	●	●
Tie hooks	●	●
Articulation lock in the transport position	●	●
Towing hitch	●	●
Tyres 26.5 R25 (L3)	●	●
Tyres 26.5 R25 (L2)	○	○
Tyres 26.5 R25 (L5)	○	○
Tyres 29.5 R25 (L3)	○	○
Tyres 29.5 R25 (L5)	●	●
Automatic lubrication system	●	●

➤ Maintenance

	DL450-5	DL550-5
Hydraulic reversing engine fan	●	●
"CORE TMS" Telematic system	●	●
Self-diagnosis system & monitoring indicator by the dashboard, plus electronic plug for fast adjustment	●	●
Fast couplers for hydraulic check	●	●
External drains for engine oil and coolant changes	●	●
Bio oil	○	○
3-year warranty	○	○
Protection+ warranty	○	○

Standard: ●
Optional: ○



Fingertip control



Limited slip differential



High lift arm



Protection+ warranty



Heavy-duty tyre



Attachments

Some of these options may be standard in some markets. Some of these options may not be available for certain markets. Please check with your local DOOSAN dealer for more information about availability or to adapt your machine to your application needs.



"CORE TMS" Doosan Telematic system: is the technology of sending, receiving and storing information via telecommunication devices in conjunction with affecting control on remote objects. In a dual mode (satellite, GSM), it provides many details about the performance of your equipment – such as operation hours, fuel efficiency, GPS, fault code/warning and reports.

SIMPLICITY WORKS

WHEN IT COMES TO DOOSAN...

